



# andromeda<sup>TM</sup>

ANDROMEDA ENERGY TECHNOLOGIES (P) LTD.



**★ INSTRUCTIONS FOR INSTALLATION, FOR CRYSTALLINE MODULES OF  
175W AND ABOVE.**

## **1.0 COMPANY INFORMATION**

Andromeda Energy Technologies (P) Ltd. (in short referred as AETPL or Andromeda) formed in May 1999, and from thereon it is engaged in manufacturing, sales and service of solar photovoltaic products (SPV) and solar thermal products. The company is promoted by core technocrats who has over a decade of experience in the solar photovoltaic industry. The company also enjoys close association with qualified professionals as well as research institutes under its purview.

Till date, Andromeda has successfully executed various Government, Semi-Government, Public and Private sector institutional orders across different product ranges and markets spread all over India.

## **2.0 QUALITY AND RELIABILITY**

Quality is not just a slogan but a need for us since there is discerning numerous customers who pay a good price for the product. Andromeda has imbibed quality into its thinking & implementation process: be it design, manufacturing, packing, logistics, sales or customer service. The efficacy of our quality system is evident with the growth in sales. When we consider our core portfolio Home Lighting systems every satisfied customer talks about the quality of our product and to the pride of our saga we have 1,00,000 customers using our products across India. Andromeda has a comprehensive Quality Assurance Program initiated right from incoming raw materials, in process controls and up to final product inspection. Andromeda company has obtained IEC 61215, IEC 61730 from TÜV (Inter-Cert) & ISO 9001 certification from TÜV Rheinland.

## **3.0 PRODUCTS – SOLAR PHOTOVOLTAIC MODULE**

Andromeda manufactures a wide range of solar photovoltaic modules starting from 140 W till 250 W. Photovoltaic modules consist of a series of electrically interconnected crystalline silicon solar cells. These cells are permanently encapsulated between a tempered glass acting as a superstrate and a polyethylene based insulator sheet called substrate. The entire laminate is secured within an anodized aluminum frame for structural strength, ease of installation and to protect the module from the most severe environmental conditions.

## **4.0 END USAGE OR APPLICATION**

Andromeda modules are direct current (DC) power source, designed to operate most efficiently under and when exposed to sunlight. Andromeda modules are maintenance-free, all they require is the front glass cleaning at regular intervals, supports typical applications like, power remote homes, water pumps for domestic and agricultural usage, telecommunication systems and many other applications involving either with or without the use of batteries.

**CONTACT: ANDROMEDA ENERGY TECHNOLOGIES (P) LTD.**

**Regd off: 9-1-18 to 24, No-4, S.P. ROAD, OPP. CIVIL COURT, SECUNDRABAD 500003, AP – INDIA.**

**TEL: +91-40-27803147, FAX: +91-40-66260277**

**WEB: [www.andromedasolar.com](http://www.andromedasolar.com), EMAIL: [info@andromedasolar.com](mailto:info@andromedasolar.com).AETPL/IM/SM/002-Rev0**

## 5.0 SCOPE and LIMITATIONS

The scope of this installation manual is limited to installing the modules. Any local permits required to install the module should be obtained by the installer or the end customer. ANDROMEDA shall have no responsibility or liability whatsoever for damage or injury to persons or property, or for other loss or injury resulting from any cause whatsoever arising from improper use or installation. Under no circumstances shall ANDROMEDA be liable to any third party for any incidental, consequential or special damages, howsoever caused.

## 6.0 SITE CONDITIONS

Andromeda modules should be installed in a location where they will receive maximum sunlight throughout the year and the area of installation should be shadow free. Basing on the geographical locations the modules should be installed facing the SUN. If the modules are not installed with appropriate orientation then the module will produce lower power than it is supposed to produce. The reduction in the module performance is almost linear to the degree of deviation in the orientation. When choosing a site, avoid trees, buildings or obstructions, which could cast shadows on the modules. Consider the site specific conditions while installing the module. Even though the factory fitted bypass diodes of the module will work to minimize any such loss, shading causes loss of output. Do not install the module near flame or flammable materials. Do not install the module in a location where it would be immersed in water or continually exposed to water from a sprinkler or fountain etc.

## 7.0 REQUISITES FOR INSTALLATION

Before installing the modules, the customer or the installer should be thoroughly aware of the requisites for installation.

- ★ Solar Modules are source of High wattage, adequate care should be taken for electric protection. The modules should be installed by qualified person only. Please check with your local authorities for the information on the qualified personnel to install the modules.
- ★ The modules should be installed in a shadow free region.
- ★ The site specific requirements like, module orientation, module tilt angle (see Figure-1) etc, should be thoroughly understood or an expert orientation is obtained or contact the company to know the exact details required to install the modules. As a thumb rule, tilt angle is the angle between (horizontal) ground and the solar module. Recommended tilt angles for a Fixed mounting system (see table -1).
- ★ Systems should be installed by qualified personnel only. It involves electricity, and can be dangerous if the personnel are not familiar with the appropriate safety procedures.
- ★ The module frame is made of anodized aluminum, and therefore corrosion can occur if the module is subject to a saltwater environment with contact to a rack of another type of metal (Electrolysis Corrosion).
- ★ If required, PVC or stainless steel washers can be placed between the module frame and support structure to prevent corrosion.
- ★ Module support structures that are to be used to support modules at correct tilt angles should be wind and snow load rated for use by the appropriate local and civil codes prior to installation.

**CONTACT: ANDROMEDA ENERGY TECHNOLOGIES (P) LTD.**

**Regd off: 9-1-18 to 24, No-4, S.P. ROAD, OPP. CIVIL COURT, SECUNDRABAD 500003, AP – INDIA.**

**TEL: +91-40-27803147, FAX: +91-40-66260277**

**WEB: [www.andromedasolar.com](http://www.andromedasolar.com), EMAIL: [info@andromedasolar.com](mailto:info@andromedasolar.com). AETPL/IM/SM/002-Rev0**

## 8.0 MODULE MOUNTING

- ★ **SCREW FITTING:** Using corrosion-proof screws (M8) on the existing installing holes in the module frame, see figure – 3.
- ★ **CLAMP FITTING:** Using suitable module clamps on the module frame, to mount the modules on the frame considering both types of module orientations “horizontal and vertical placing of module with reference to facing the sun and the ground. The clamp should not touch the front glass of the module and should not be thick to create a shadow on the module, see figure-3.
- ★ The frame of each module has 4 mounting holes (12mm×8mm) used to secure the modules to supporting structure. The module frame must be attached to a supporting structure using stainless steel hardware together with spring washers and flat washers in four places symmetrical on the module.
- ★ The applied torque is about ~8 Newton-meters.
- ★ The module clamps must not come into contact with the front glass and must not deform the frame.
- ★ Avoid shadowing effects from the module clamps and the insertion systems.
- ★ It is not permitted to modify the module frame under any circumstances.
- ★ Recommended gap between 2 Solar modules, or module and mounting structure is 5mm.
- ★ Clearance between the module frame and mounting surface may be required to prevent the junction box from touching the surface, and to circulate cooling air around the back of the module.
- ★ The modules are not designed for integral mounting as part of a roof or wall.
- ★ The mounting design may have an impact on the fire resistance. If the modules are to be installed on the roof or wall of a building, the fire resistance of roof covering or wall should be rated for the application.
- ★ If the modules are installed on a building wall or roof, the modules are supported parallel to the surface of the roof or building wall. Clearance between the module frames and surface of the wall or roof is required to prevent wiring damage and to allow air to circulation behind the module. The minimum clearance (of about 115 mm) between the module and the roof. Any other clearances are used then the listing in the fire class ratings may be effected. Any slope less than 5in/ft (127mm/305mm) required to maintain a fire class rating.
- ★ Do not mount SPV module in such way that the drain holes of SPV module are intended to block up.
- ★ Do not step on the module during installation and after installation.

## 9.0 GROUNDING REQUISITES

- ★ Each Module is provided with a 3.9 mm dia hole, in both the Length channels to connect the grounding cable (see figure-2).
- ★ Proper grounding is achieved by connecting the module frame(s) and structural members contiguously one to another using a suitable grounding conductor. This must be properly done in accordance with the National Electrical Code (NEC) or as per National Regulations.
- ★ The grounding conductor should be copper or copper alloy or other material acceptable for use as per NEC. The

**CONTACT: ANDROMEDA ENERGY TECHNOLOGIES (P) LTD.**

**Regd off: 9-1-18 to 24, No-4, S.P. ROAD, OPP. CIVIL COURT, SECUNDRABAD 500003, AP – INDIA.**

**TEL: +91-40-27803147, FAX: +91-40-66260277**

**WEB: [www.andromedasolar.com](http://www.andromedasolar.com), EMAIL: [info@andromedasolar.com](mailto:info@andromedasolar.com).AETPL/IM/SM/002-Rev0**

conductor should be connected to a module with abolt and nut that incorporates an external tooth washer.

- ★ The ground cable of all modules in an array should be interconnected and then is connected to the mounting structure. The mounting structure also needs to be grounded in accordance with NEC.
- ★ The grounding conductors must then make a connection to earth using a suitable earth ground electrode. Attach a separate conductor to one of the grounding holes on the module frame with abolt and nut that incorporates an external tooth washer. This is to ensure positive electrical contact with the frame.

## **10.0 BYPASS DIODES AND BLOCKING DIODES**

Partial shading of an individual module can cause a reverse voltage across the shaded module. Current is then forced through the shaded area by the other modules. When a bypass diode is wired in parallel with the series string, the forced current will flow through the diode and bypass the shaded module, thereby minimizing module heating and array current losses. In system utilizing a battery, blocking diodes are typically placed between the battery and the SPV module output to prevent battery discharge at night, and prevent modules from loss of array output and being damaged or destroyed by reverse current flow. Our modules are not fitted with blocking diodes, however most PV charge controller or Inverter do provide blocking diodes, customer are requested to check with the respective component supplier. We use, Diotec make "F1200D" series bypass diode, the specifications of the same can be obtained from [www.diotec.com](http://www.diotec.com), alternatively a copy of our bypass diodes can be obtained from us via email and the same is recommended to be used by the customer.

## **11.0 WARNING AND NOTES**

- ★ The modules generate electricity when exposed to light. Array of many modules can cause lethal shock and burn hazards. Only authorized and trained personnel should have access to these modules. To reduce the risk of electrical shock or burns, modules maybe covered with an opaque material during installation to avoid shocks or burns.
- ★ Do not touch live terminals with bare hands.
- ★ Use insulated tools for electrical connections.
- ★ Use appropriate methods to mount SPV modules.
- ★ Fall of modules from high place will cause death, injury or damage.
- ★ The module has a pair of male and female waterproof connectors. For a series electrical connection, connect positive (+) connector of first module to negative (-) connector of the following module.
- ★ Do not short the positive and the negative.
- ★ Do not disconnect under load.
- ★ Be sure connector no gap between the insulators.
- ★ In case there is a gap, a fire and/or an electrical shock may occur.
- ★ Artificially concentrated sunlight shall not be directed on the SPV module.
- ★ The electrical characteristics are indicated value of Pmax under standard test conditions (Irradiance of 1000W/m<sup>2</sup>, AM 1.5 spectrum, and cell temperature of 25°C).
- ★ Under field conditions, a solar photovoltaic module is likely to experience conditions that produce more or less current and/or voltage than reported at standard test conditions.

**CONTACT: ANDROMEDA ENERGY TECHNOLOGIES (P) LTD.**

**Regd off: 9-1-18 to 24, No-4, S.P. ROAD, OPP. CIVIL COURT, SECUNDRABAD 500003, AP – INDIA.**

**TEL: +91-40-27803147, FAX: +91-40-66260277**

**WEB: [www.andromedasolar.com](http://www.andromedasolar.com), EMAIL: [info@andromedasolar.com](mailto:info@andromedasolar.com).** AETPL/IM/SM/002-Rev0

## 12.0 MODULE WIRING

- ★ Each module has two #12 AWG type standard 90°C sunlight resistant output cables each terminated with plug & play connectors. This cable is suitable for applications where wiring is exposed to the direct rays of the Sun. We recommend that all wiring and electrical connections comply with the National Electrical Code (NEC). For field connections, use the minimum No. #12 AWG copper wires insulated for a minimum of 90°C and sunlight resistant as well.
- ★ The minimum and maximum outer cable diameters of the cable are 5 to 7mm. Refer to local regulations on designing the cable size as per maximum electrical rating of series fuse.

## 13.0 MAINTENANCE

- ★ Under most weather conditions, normal rainfall is sufficient to keep the module glass surface clean. If dirt build-up becomes excessive, clean the glass only with a soft cloth using mild detergent and water.
- ★ USE CAUTION WHEN CLEANING THE BACK SURFACE OF THE MODULE TO AVOID PENETRATING THE SUBSTRATE MATERIALS.
- ★ Modules that are mounted flat (0° tilt angle) should be cleaned more often, as they will not "self clean" as effectively as modules mounted at tilt or greater.
- ★ Once a year, check the tightness of terminal screws and the general condition of the wiring. Also, check to be sure that mounting hardware is tight.
- ★ Loose connections will result in damage for array. Changed module must be the same kind and type.
- ★ Do not touch live parts of cables and connectors.
- ★ Use appropriate safety equipment (insulated tools, insulating gloves, etc.), when touching them.
- ★ Do not forget to cover the front surface of the module by an opaque or other material when repairing.
- ★ The modules when exposed to sunlight generate high voltage and are dangerous.

## 14.0 APPLICATION CLASSES

Our modules are designed and qualified to be used in Application class "A", and (safety classes are defined within EN 61140)

- i) Application class "A", considered to meet the requirements for safety class II. Modules rated for use in this application class may be used in systems operating at greater than 120 V DC.

**CONTACT: ANDROMEDA ENERGY TECHNOLOGIES (P) LTD.**

**Regd off: 9-1-18 to 24, No-4, S.P. ROAD, OPP. CIVIL COURT, SECUNDRABAD 500003, AP – INDIA.**

**TEL: +91-40-27803147, FAX: +91-40-66260277**

**WEB: [www.andromedasolar.com](http://www.andromedasolar.com), EMAIL: [info@andromedasolar.com](mailto:info@andromedasolar.com).AETPL/IM/SM/002-Rev0**

## 15.0 SPECIFICATIONS

The electrical and physical specifications are given in Table -2, at the last page of this document.

Notes:

- The electrical characteristics are indicated values of Pmax measured at Standard Test Conditions (STC).
- Under certain conditions a photovoltaic module may or likely to produce more current and or voltage than reported at the standard test conditions. Accordingly the values of Isc and Voc marked on this module should be multiplied by a factor 1.25 when determining component voltage ratings, conductor ratings, fuse sizes and sizes of regulators which are connected to PV output. Also refer to relevant National electric codes for additional multiplying factors as applicable.
- Our modules are designed to function in a system with a maximum system voltage of 1000 V DC.
- The recommended maximum number of modules in to be connected in series,

No. of cells in a Module	Module Voc	No. of Modules in Series
40	≤ 24.5 V	$(1000 \text{ V} / 24.5 \text{ V} = 40.8) = \sim 40$
48	≤ 29.0 V	$(1000 \text{ V} / 29.0 \text{ V} = 34.4) = \sim 34$
50	≤ 30.7 V	$(1000 \text{ V} / 30.7 \text{ V} = 32.5) = \sim 32$
54	≤ 32.7 V	$(1000 \text{ V} / 32.7 \text{ V} = 30.5) = \sim 30$
60	≤ 36.7 V	$(1000 \text{ V} / 36.7 \text{ V} = 27.2) = \sim 27$

- For maximum number of modules in parallel configuration, please refer to capacity of current carrying controllers. Load regulators, frequency variators, or related equipment to which max. current load can be accepted. However, a suitable cross section of cable must be used for conducting the total current from modules and the recommended protection fuse rating of 12A to be used for modules in parallel configuration.

FIGURE -1

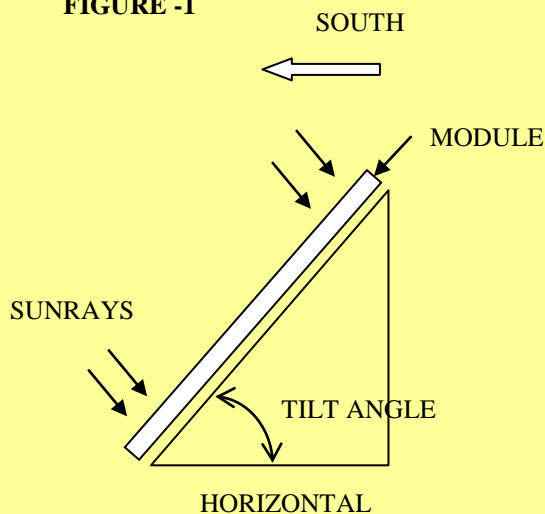

TABLE -1

Recommended Tilt angles for Fixed Systems	
Month	Fixed Tilt Angle
February 21	Latitude of Site ( <b>LS</b> )
April 21	<b>LS - 16°</b>
August 21	<b>LS</b>
October 21	<b>LS + 15°</b>
Please change the Tilt angle 4 times a year to have maximum power output from the module. If you do not wish to change then you can set up at <b>LS - 16°</b>	

**CONTACT: ANDROMEDA ENERGY TECHNOLOGIES (P) LTD.**

Regd off: 9-1-18 to 24, No-4, S.P. ROAD, OPP. CIVIL COURT, SECUNDRABAD 500003, AP – INDIA.

TEL:+91-40-27803147, FAX: +91-40-66260277

WEB: [www.andromedasolar.com](http://www.andromedasolar.com), EMAIL: [info@andromedasolar.com](mailto:info@andromedasolar.com).AETPL/IM/SM/002-Rev0

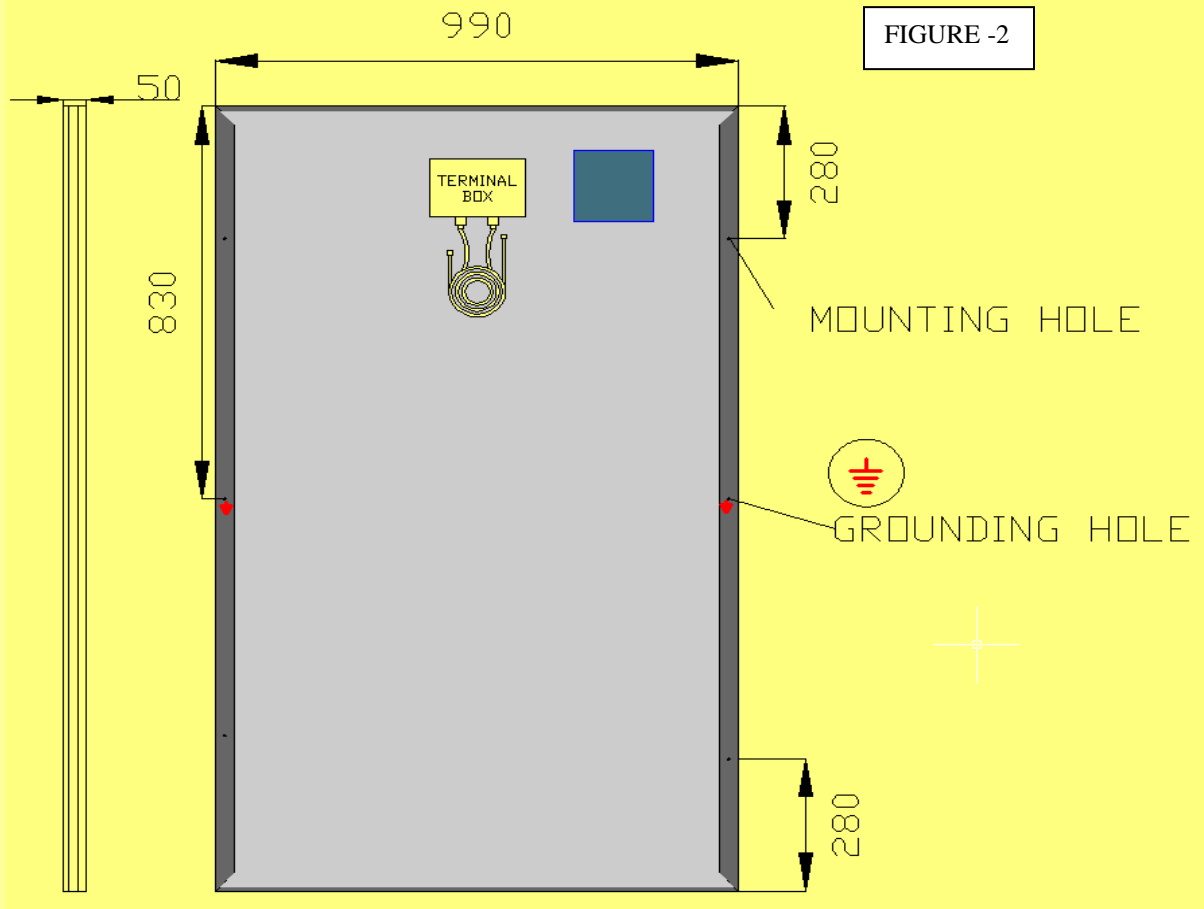
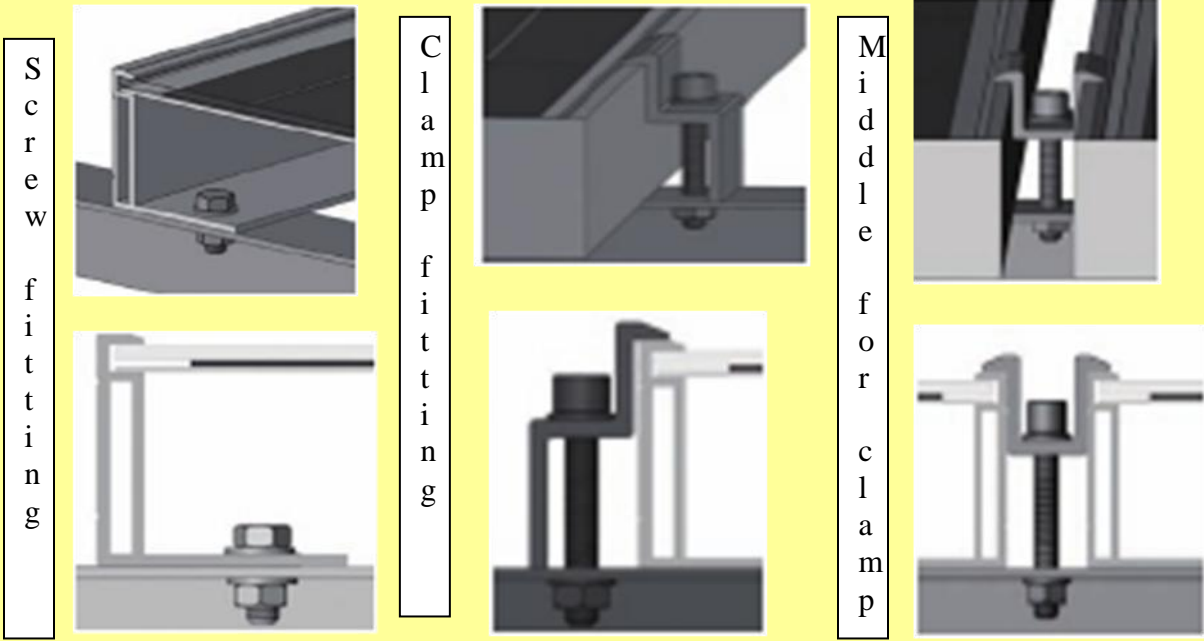

Figure - 3



**CONTACT: ANDROMEDA ENERGY TECHNOLOGIES (P) LTD.**  
 Regd off: 9-1-18 to 24, No-4, S.P. ROAD, OPP. CIVIL COURT, SECUNDRABAD 500003, AP – INDIA.  
 TEL:+91-40-27803147, FAX: +91-40-66260277  
 WEB: [www.andromedasolar.com](http://www.andromedasolar.com), EMAIL: [info@andromedasolar.com](mailto:info@andromedasolar.com).AETPL/IM/SM/002-Rev0

**TABLE - 2**

<b>ELECTRICAL SPECIFICATIONS</b>														
Parameter	Units	Model Number : Andromeda made, "MMO" series with 6 inch Mono Crystalline solar cells												
Power at Peak	[W]	180	185	190	195	200	205	210	215	220	225	230	235	240
V at Peak	[V]	24.10	24.34	24.58	25.45	25.90	27.27	27.49	27.97	28.49	30.12	30.42	30.54	31.08
I at Peak	[A]	7.46	7.60	7.73	7.66	7.72	7.51	7.64	7.67	7.72	7.47	7.56	7.69	7.72
V at Open Circuit	[V]	28.75	28.85	29.09	30.15	30.40	32.40	32.56	32.83	33.10	35.94	36.06	36.18	36.48
I at Short Circuit	[A]	8.18	8.25	8.33	8.29	8.38	8.20	8.29	8.38	8.38	8.18	8.25	8.29	8.38
Max Sys Voltage	[V]	1000	1000	1000	1000	1000	1000	1000	1000	1000	1000	1000	1000	1000
Bypass Diode	[A]	15	15	15	15	15	15	15	15	15	15	15	15	15
No of Diodes	No	3	3	3	3	3	3	3	3	3	3	3	3	3
Series Fuse Rating	[A]	12	12	12	12	12	12	12	12	12	12	12	12	12
<b>TEMPERATURE COEFFICIENTS</b>														
Voc	[V/°K]	-0.125												
Isc	[A/°K]	+0.00178												
Ppk	[W/°K]	-1.093												
<b>PHYSICAL CHARACTERISTICS</b>														
Length	[mm]	1350	1350	1350	1660	1660	1500	1500	1500	1500	1660	1660	1660	1660
Width	[mm]	990	990	990	830	830	990	990	990	990	990	990	990	990
Thickness	[mm]	50	50	50	50	50	50	50	50	50	50	50	50	50
Mounting slot pitch	[mm]	225	225	225	280	280	250	250	250	250	280	280	280	280
Mounting slot dia	[mm]	8×12	8×12	8×12	8×12	8×12	8×12	8×12	8×12	8×12	8×12	8×12	8×12	8×12
Grounding hole pitch	[mm]	675	675	675	830	830	750	750	750	750	830	830	830	830
Grounding hole dia	[mm]	3.9	3.9	3.9	3.9	3.9	3.9	3.9	3.9	3.9	3.9	3.9	3.9	3.9
Drain hole dia	[mm]	4.5	4.5	4.5	4.5	4.5	4.5	4.5	4.5	4.5	4.5	4.5	4.5	4.5

- Note:
- 1) The parameters are measured at Standard Test Conditions (STC), of irradiance 1 kW/m<sup>2</sup>, air spectrum AM 1.5, and at module temperature of 25°C.
  - 2) Normal Operating Conditions of irradiance 800 W/m<sup>2</sup>, Air spectrum of 1.5, and at module temperature of 25°C.
  - 3) Please refer latest specifications and drawings on our website [www.andromedasolar.com](http://www.andromedasolar.com).

1<sup>st</sup> October 2011, HYDERABAD

  
 M.N.Mahesh  
 Vice President (OP)

**CONTACT: ANDROMEDA ENERGY TECHNOLOGIES (P) LTD.**

**Regd off: 9-1-18 to 24, No-4, S.P. ROAD, OPP. CIVIL COURT, SECUNDRABAD 500003, AP – INDIA.**

**TEL:+91-40-27803147, FAX: +91-40-66260277**

**WEB: [www.andromedasolar.com](http://www.andromedasolar.com), EMAIL: [info@andromedasolar.com](mailto:info@andromedasolar.com).AETPL/IM/SM/002-Rev0**